

Luxart® VitaBella

**Free Standing
Bathtubs**

Installation Instructions



Installation instructions for qualified fitters. After the installation, please pass these instructions to the end-user. In case of a claim, the installation and disassembly costs shall not be covered by the warranty. The warranty shall be valid provided that the product has been installed in accordance with these instructions.



Luxart® VitaBella

Installation Instructions

Free Standing Bathtubs

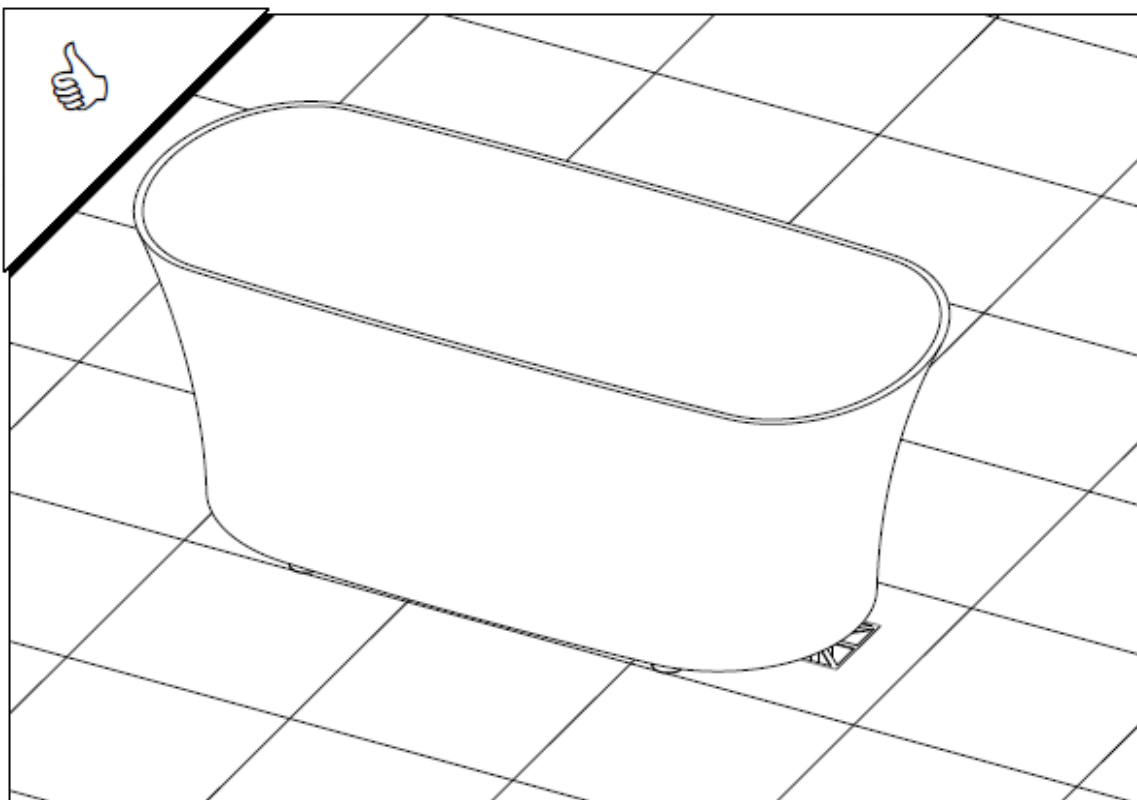
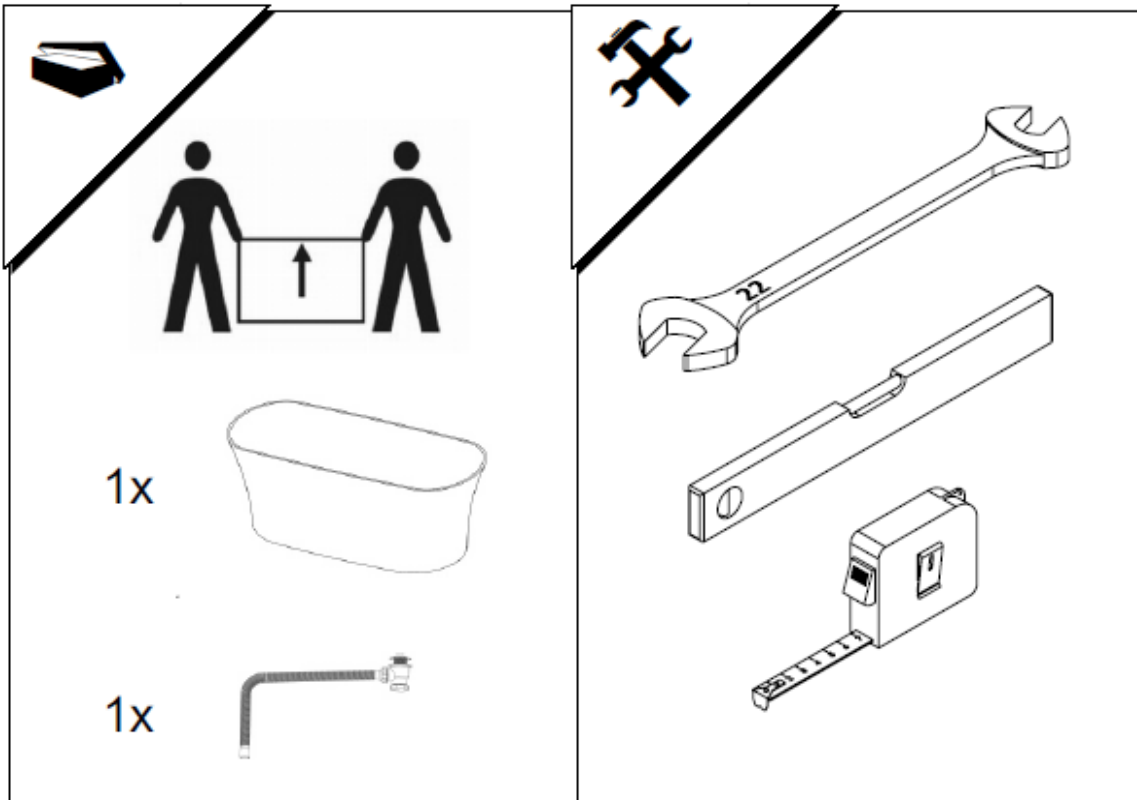

Luxart® VitaBella

Installation Instructions

Free Standing Bathtubs

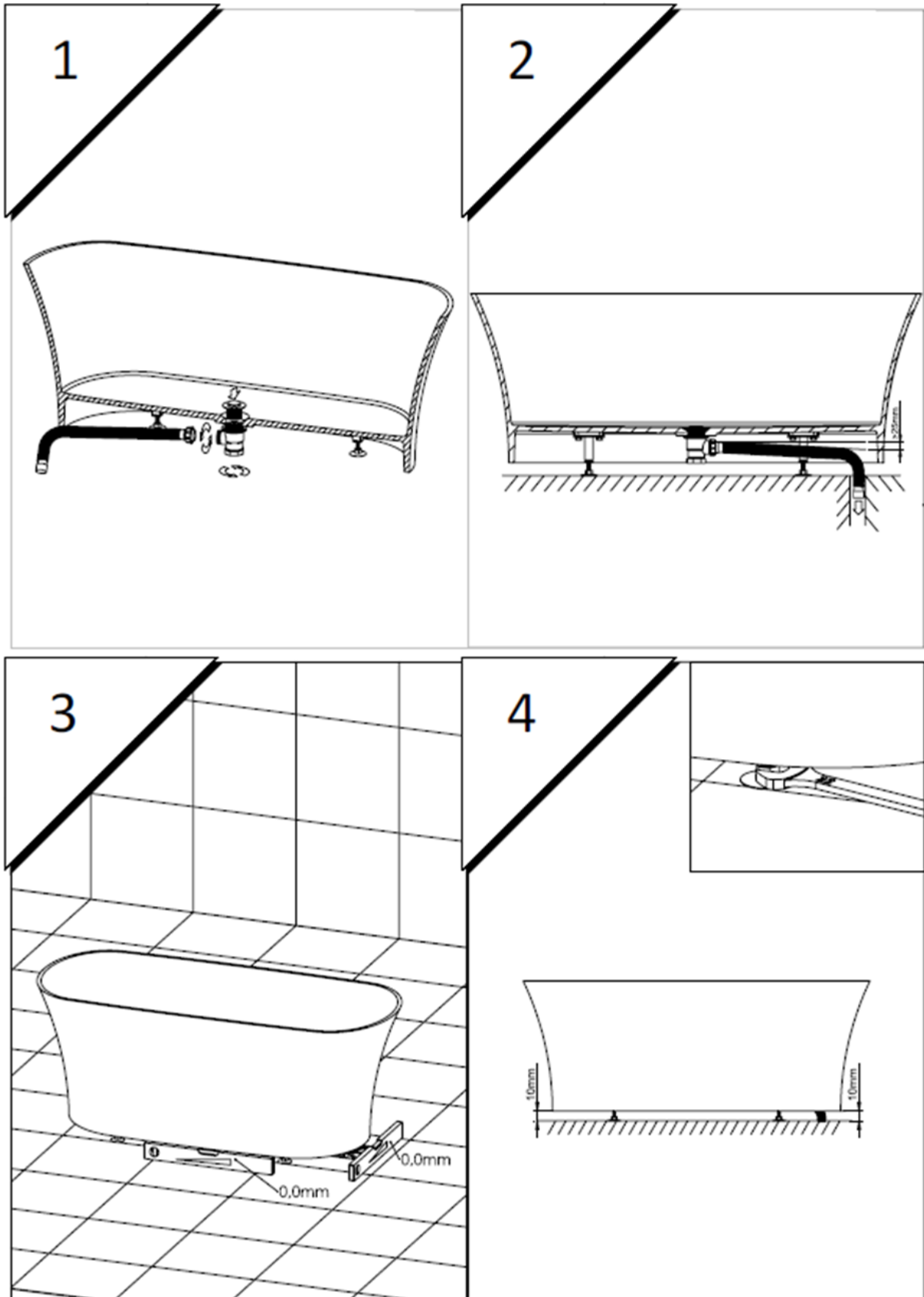

Installation Instructions

Care & Cleaning Guidelines

The surface of all our products is among the highest quality surfaces available, made of Mineral Composite. With normal use, the surface will retain its beauty with only a minimal amount of care.

ABOUT THE MINERAL COMPOSITE

Every Mineral Composite product has a minimum dolomite content of 75%. It's external surface is covered with nanocoat.

The material fully utilizes the properties of dolomite stone, while being reinforced with a flexible resin binder to ensure resistance under load, damage from impact and the effects of high and low temperatures.

Products made from Mineral Composite maintain an optimal temperature for a long time. They are always warm to the touch and provide unprecedented comfort in the bathroom. Due to the inherent strength of the nanocoat surface products are always pleasant to the touch and have a smooth finish. Mineral Composite's insusceptibility to bacterial growth, absorption of water and chemical substances, ensure a long lasting quality and ease of care.

For standard cleaning, we recommend using widely available non-abrasive cleaning products.

NOTE: TO MAINTAIN THE BEAUTY OF THE PRODUCT SURFACE AND AVOID UNWANTED STAINS (HAIR DYE, INK, LIPSTICK AND OTHER COLOURING MATTER) WE STRONGLY RECCOMEND THE IMMEDIATE REMOVAL OF DIRT. THE TEMPERATURE OF THE WATERSHOULD NEVER EXCEED 70° C FOR A WASHBASIN AND 75° C FOR A BATH OR AND SHOWER TRAY.

AVOID ANY BATH CLEANING PRODUCTS THAT CONTAIN NATURAL OR ARTIFICIAL DYES, TEST PRODUCT ON AN INCONSPICUOUS AREA BEFORE USING.

IMPROPER USE MAY DAMAGE PRODUCTS AND INVALIDATE THE WARRANTY.

RECOMMENDATION FOR GLOSS FINISHES

1. For regular cleaning use of universal cleaning agents with nonabrasive properties, or any mild dish soap and water or product specifically made for gloss surfaces.
2. After each use the inner surface must be rinsed with water and cleaned with a cotton cloth.
3. In order to maintain the product aesthetics we recommend using wax once per month.
4. Stronger dirt (grease, mildew, oil, paint or ink stains) must be treated with warm water and gentle cleaning agents or a soap solution with water.
5. Never use any abrasive cleaners. If any product feels gritty when rubbed between your fingers then it is not safe to use on your gloss product.
6. Small scratches can be removed by using a polishing paste.
7. Scratches on the surface may be treated with abrasive paper soaked in water. First try a 1500 grit paper, then if needed try a 3000 grit paper. Afterwards, the surface may be polished with a fine grained polishing paste (for painted surface).
8. Limescale may be treated with a solution of water and vinegar.

RECOMMENDATION FOR MATT FINISHES

1. For regular cleaning use a universal cleaning agent with nonabrasive properties, or any mild dish soap and water.
2. After each use the inner surface must be rinsed with water and cleaned with a cotton cloth.
3. For more stubborn stains (grease, mildew, oil, paint or ink stains), use a mild abrasive cleaner. It may take a little more scrubbing to actually remove marks. **NOTE: PLEASE BE CAREFUL WITH ALL PRODUCTS CONTAINING ABRASIVES.**
4. In order to maintain the aesthetics of a product it is recommended to use skin care oil once per month.
5. Stronger dirt must be treated with warm water, with gentle cleaning agents or a soap solution with water.
6. Scratches on the surface may be treated with a rough sponge and then maintained with oil. Limescale may be treated with a solution of water and vinegar.

SCRATCHED OR DAMAGED SURFACES

To repair scratched or damaged surfaces please see point 7 or use our dedicated **REPAIR KIT**.



Luxart® VitaBella

LUXART MINERAL COMPOSITE TUBS RESIDENTIAL LIMITED WARRANTY TERMS AND CONDITIONS

Luxart provides a limited warranty for all MINERAL COMPOSITE® tubs for use to the original purchaser for personal or single family use. Luxart warrants these tubs to be free of defects in material and workmanship during use by the original purchaser for a period of 5 years.

Subject to the terms contained herein, Luxart will repair or replace a defective product or refund the purchase price. In no event shall the Seller's liability under this warranty exceed the cost of repair or replacement of the product or the purchase price of the product. Feet, drains, faucets and accessories are not covered under this warranty.

The warranty does not extend to:

1. Damage caused by cleaning, maintenance or installation performed other than strictly in accordance with the information contained in Care Instruction.
2. Damage due to installation error (see Clean & Care Instructions), product neglect, misuse, or abuse, accident or negligence, whether caused by the purchaser, a contractor or a service provider or any other cause beyond the control of Luxart.
3. Damage or failure caused by common carrier.
4. Modification of any type for any reason.
5. Damage caused by the use of strong chemicals.
6. Staining from food or beverages (such as red wine), medicinal products (such as mecurochrome), make-up, etc.
7. Finish reduction, scratching or staining of the finish over time due to water impurities or atmospheric conditions.
8. Extraordinary acts such as earthquakes, hurricanes, lightning, floods, hail, etc.

The company will replace or repair the defective product subject to the following conditions:

1. Claim is made in writing to head office within 10 days of the problem being apparent;
2. Product has been appropriately water tested for leaks and inspected prior to completing installation.
3. The product has been used in the manner that it was intended, this protection does not apply to any products that have been misused in any way;
4. The product must have been installed and cared for in line with our fitting instructions and local water bylaws.

(See Clean & Care instruction for proper cleaning, maintenance, and installation information.)



To file a claim contact:

LUXART CUSTOMER SERVICE
EMAIL: MLCUSTOMERSERVICE@HAJOCA.COM

Please be sure to provide all pertinent information regarding your claim, including a complete description of the problem, the model name and number and the date and place of purchase. Also include your original invoice. In order to assess any claim, we may have to inspect the product as installed before removal and must be provided with access to the product upon request.

Except as provided herein, seller makes no warranty of any kind, express or implied, with respect to the product, its merchantability, or fitness for a particular purpose. Seller shall not be responsible for any indirect, incidental, or consequential damages resulting from the delivery, installation, or use of the product.

Display floor models and overstock sale units are excluded from this warranty. See commercial warranty for commercial installation coverage.



Luxart® VitaBella

LUXART MINERAL COMPOSITE TUBS COMMERCIAL LIMITED WARRANTY TERMS AND CONDITIONS

Luxart provides a limited warranty for all MINERAL COMPOSITE® tubs for use to the original purchaser for commercial, rental or multifamily application. Warranty coverage begins from date of purchase (regardless of installation date).

Two-Year Bath Shell Warranty: Luxart warrants MINERAL COMPOSITE® tubs not to peel, crack, blister, or discolor for a period of two years from date of purchase.

The company will replace or repair the defective product subject to the following conditions:

1. The product must have been installed and cared for in line with our fitting instructions and local water bylaws. (See Clean & Care instruction for proper cleaning, maintenance, and installation information.)
2. Claim is made in writing to our customer service within 10 days of the problem being apparent;
3. Product has been appropriately water tested for leaks and inspected prior to completing installation.
4. The product has been used in the manner that it was intended, this protection does not apply to any products that have been misused in any way.

The warranty does not extend to:

1. The cost of removing or reinstalling the unit, or costs associated with any adjacent materials.
2. Leaks associated with improper waste and overflow installation.
3. Blemishes, air holes or casting marks on the underside of the bath. These are not considered defects and do not affect the performance or quality of the bath. Slight variations in the surface are indigenous to the natural stone appearance of the product and are not considered defects or flaws. Variations in the surface do not compromise the structural integrity of the product.
4. A Unit that is not water tested for leaks and inspected prior to completing installation.
5. Drain leakage. Proper drain installation is the responsibility of the installer.
6. Careless handling;
7. Modification of any type for any reason
8. Incorrect or inadequate water use;
9. Damage due to installation error (see Clean & Care Instructions), product neglect, misuse, or abuse, accident or negligence, whether caused by the purchaser, a contractor or a service provider or any other cause beyond the control of Luxart.
10. Damage or failure caused by common carrier. The consignee must open and inspect the unit for damage when it is delivered. If the unit is damaged, this must be reported immediately to both the seller and the carrier in writing and an inspection must be requested. Any freight claims must be filed within ten business days.
11. Damage caused using improper cleaners or chemicals.



12. Staining from food or beverages (such as red wine), medicinal products (such as mercurochrome), make-up, etc.
13. Finish reduction, scratching or staining of the finish over time due to water impurities or atmospheric conditions.
14. Extraordinary acts such as earthquakes, hurricanes, lightning, floods, hail, etc.
15. Failure or damage that should have been discovered, repaired and avoided by proper inspection and testing prior to installation.
16. Incidental or consequential damage, loss of time, inconvenience, incidental expenses, labor or material charges or any other costs related to the application of this warranty.
17. Water damage to carpeting, floors or ceilings.
18. Optional equipment not manufactured by Luxart or installed by Luxart
19. Damages or defects that should be detected before installation are not covered.
20. Labor, transportation, or other costs incurred in the removal and/or reinstallation of the original unit or replacement unit. Costs related to obtaining access for repair.

Warranty Limitations: Chips, cracks, and scratches can be repaired by a qualified technician at the owner's/user's expense.

Extent of Warranty: This warranty extends only to the original consumer/purchaser of the Luxart MINERAL COMPOSITE® product when purchased and originally installed within the boundaries of the continental USA. The warranty terminates after transfer of ownership or if the tub is installed or relocated outside the boundaries of the continental USA by the original consumer/purchaser prior to the expiration of the warranty period. Display floor models and overstock sale units are excluded from this warranty.

Warranty Performance: In the event of any malfunction or defect covered under the terms of this warranty, a Factory Authorized Service Agent of Luxart will repair the MINERAL COMPOSITE® product. To obtain service, contact Luxart Customer Service for an agent in your area and issuance of a service order number. No work/payment will be made without an authorized service order number. There will be no charge for parts, labor or freight costs for parts necessary to repair the tub under warranty. Written notice of any malfunction or defect must be given within ten days of the time the malfunctions were discovered, and must be accompanied by proof of purchase.

Luxart reserves the right to inspect the malfunction or defect on site and repair or replace the unit at our discretion.

Disclaimers: The foregoing warranty is EXCLUSIVE and in lieu of all other warranties, including any other warranty of quality, express or implied, and including any warranty of merchantability, or any warranty of fitness for any particular purpose.

To verify coverage, request service or file a claim, please contact:

LUXART CUSTOMER SERVICE
EMAIL: MLCUSTOMERSERVICE@HAJOCA.COM

Please have serial or registration number available.

